

## Ram Air Scoop for R56 MINI Cooper S - 2007+ REFRESH KIT

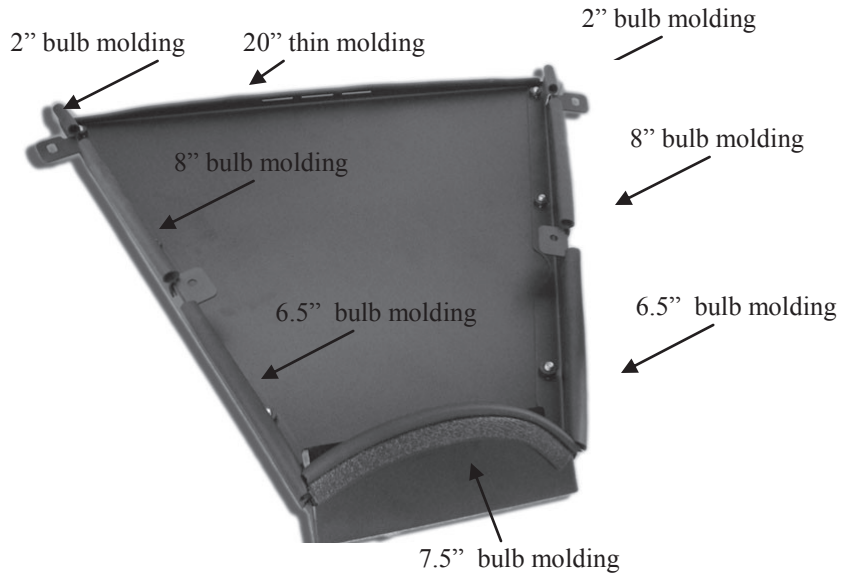
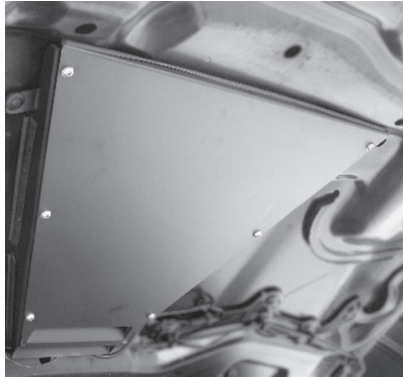

TOOLS NEEDED
Sharp scissors or shears
4mm Allen key

- Before you do any work under your bonnet you need to do the following:**
1. Make sure the car has had time to cool as you will be working close to the engine.
  2. Disconnect the negative terminal from the battery.

PACKING LIST	
Description	Qty
7.5 " bulb molding	1
6.5" bulb molding	2
8" bulb molding	2
2" bulb molding	2
20" thin molding	1
3' of Vacuum line	1

## Removal of Ram Air Scoop (RAS)

1. Remove 6 button head bolts holding on lid.
2. Remove plastic retainers.
3. Remove old bulb and thin molding, replace with new.
4. Replace the vacuum line going from the valve cover to the fire-wall.

**THIS IS VERY IMPORTANT!!!** Make sure that the plastic nipple is facing the passenger side of the car (see picture bottom right). If you need to rotate it, There is a T-25 torx silver head bolt holding it in. Loosen this bolt and remove it. Then rotate the plastic nipple so that it is facing the passenger side of the car (see picture bottom right). Once the nipple is rotated, re-insert the bolt in the original location and gently tighten it down until it secures the nipple in place.

5. Find the supplied tubing in the refresh kit and re-connect.
6. Double check the fitment and make sure the RAS is secure and in place, and you are ready to go!

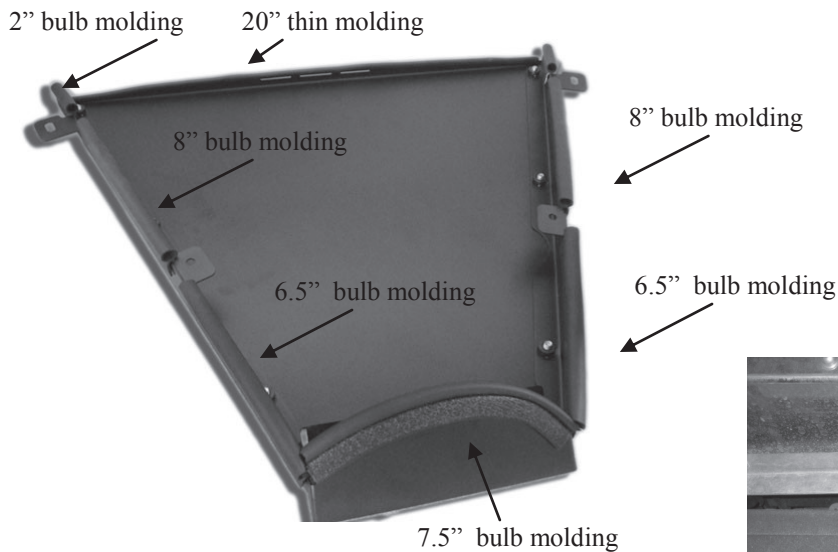
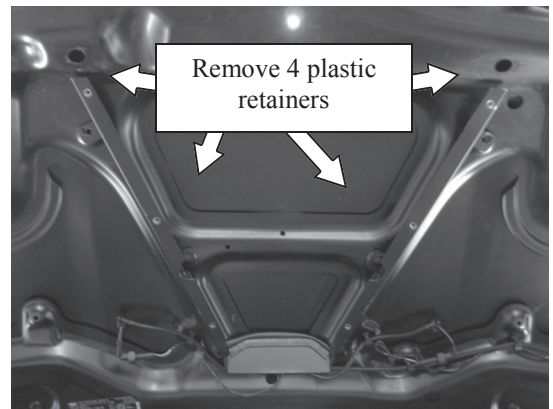
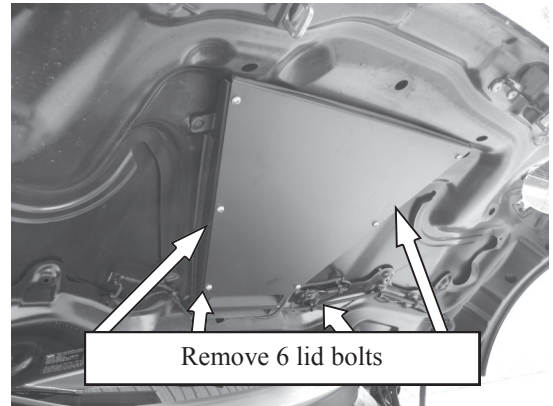

Make sure nipple is facing passenger side before installing the hose!  
**DO NOT SKIP THIS STEP!**



Rev. 0133114im